



P.O. Box 519	1351 W. Second Street	379 Davis Road, Unit #3
Corona, California 92878-0519	Oconomowoc, Wisconsin 53066	Oakville, Ontario, Canada L6J 2X2
Phone: 909-735-8220; 800-543-3885; 800-735-1922	Phone: 262-567-2288	Phone: 905-844-1791; 800-361-9473
Fax: 909-735-2372; 800-752-6001; 800-735-0857	Fax: 262-567-0857	Fax: 905-844-2533; 800-663-0933

INSTALLATION INSTRUCTIONS • 14 GAUGE C-TRACK SYSTEM

For Both Galvanized and Stainless Steel Systems

TYPICAL SYSTEM LAYOUT

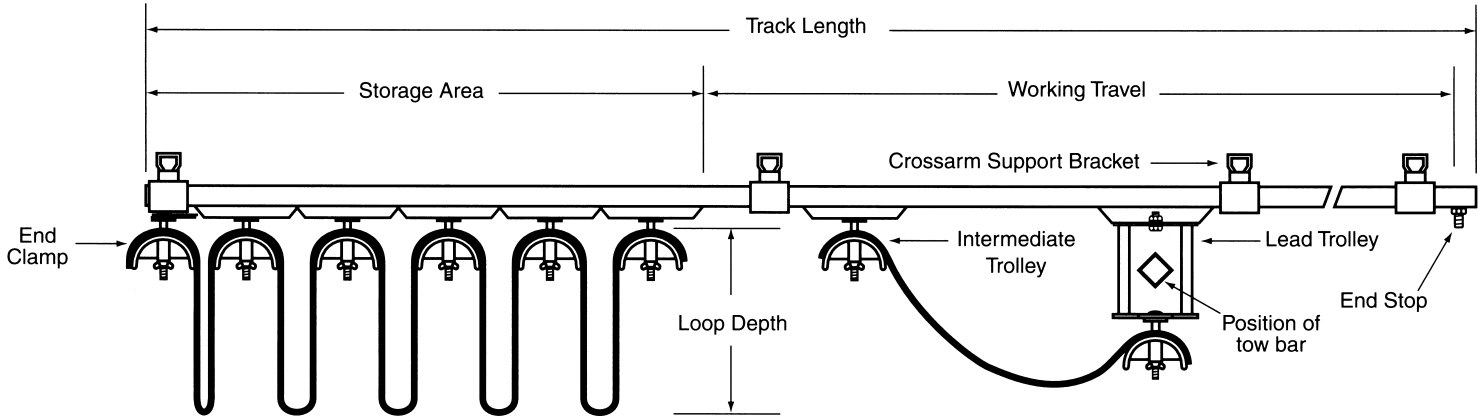

Use tow chains or straps when system speed is over 150 FPM.

Consult Factory when:

- Atmosphere is corrosive or dusty.
- Hazardous materials are present.
- Speeds exceed 250 FPM.
- Components not shown or listed are required (including special flat cable sizes.)

CAUTION

MAKE CERTAIN POWER SUPPLY IS DISCONNECTED BEFORE INSTALLING, REPAIRING, OR WORKING IN THE PROXIMITY OF ANY ELECTRICAL SYSTEM. ONLY QUALIFIED ELECTRICAL PERSONNEL SHOULD INSTALL OR REPAIR THESE PRODUCTS.

STEP 1

DETERMINE BRACKET AND HANGER SPACING

- Determine the loop depth (3 ft. is typical).
- Calculate the total load per trolley.
- Use the following guidelines to space brackets and hangers.

Trolley Load	Spacing
5 lbs.	7 ft.
10 lbs.	6 ft.
15 lbs.	5 ft.

- In the storage area of the track, space the support brackets at 5 ft.
- When installing independent pushbutton tracks, use 5 ft. spacing throughout the entire track length. Pulling the station control trolley from the floor adds additional stress on the track hangers.

STEP 2

INSTALL CROSSARM SUPPORT BRACKETS

Install crossarm support brackets using the spacing determined in Step 1.

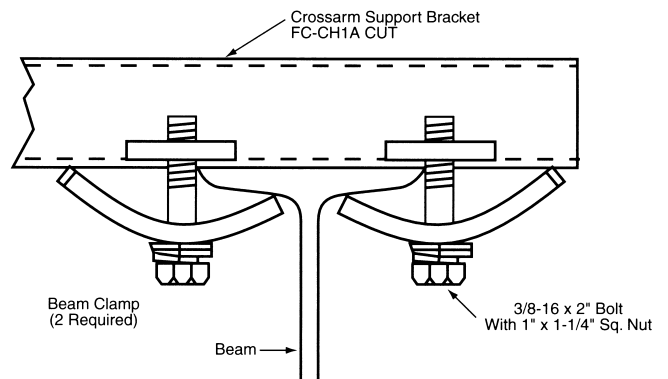

UNIVERSAL BEAM CLAMP
FC-TMC-U or FC-TMC-U-SS

STEP 3: INSTALL HANGERS

Install track hangers on crossarms, leaving clamping bolts loose.

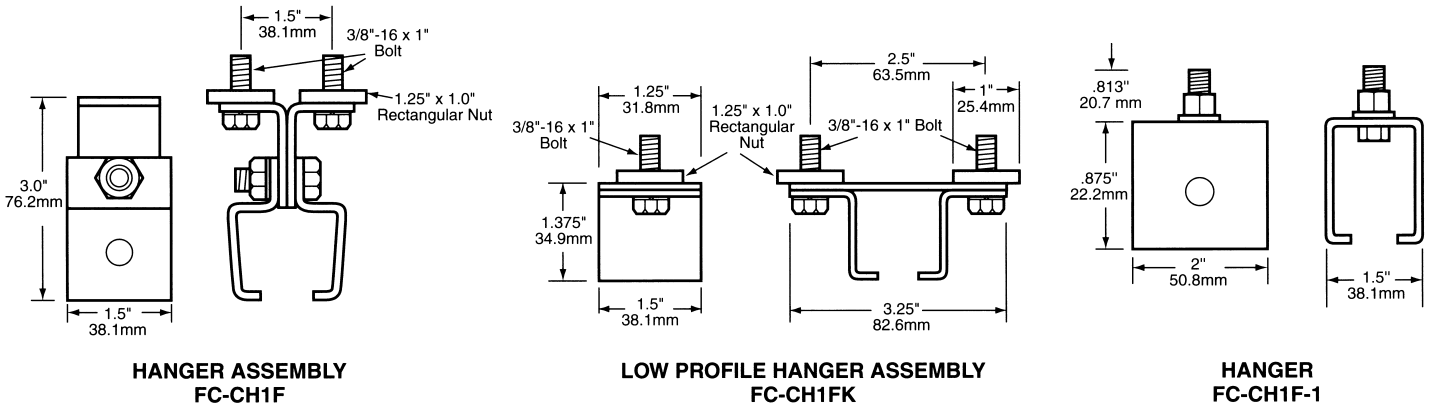

STEP 4 INSTALL C-TRACK

Slide C-Track sections into hanger clamps. Butt C-Track together and secure with track joint clamps. Firmly tighten joint clamp bolts and hanger clamping bolts, making sure that the track is straight. Curved sections must be welded to straight sections with the supplied welding sleeve. See Step 14.

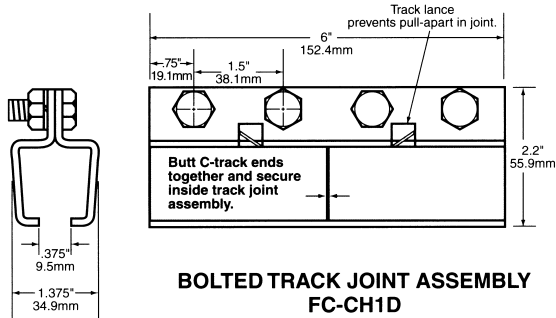

STEP 5 INSTALL ANCHOR BOLT

Drill a hole through the end hanger and secure it to the track with an anchor bolt. (Drilling is not necessary with the FC-CH1F-1-A Single Bolt Anchor/Hanger, because it comes with its own pre-installed anchor bolt.)

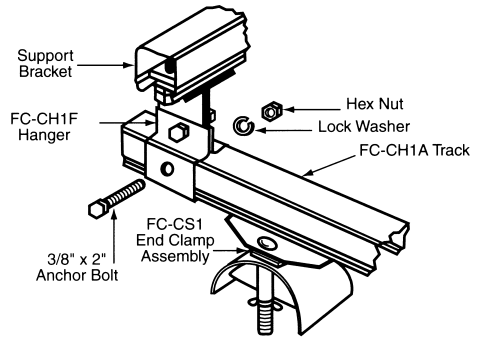

STEP 6 INSTALL END CLAMP

Install the end clamp assembly onto the cable-storage end of the track.

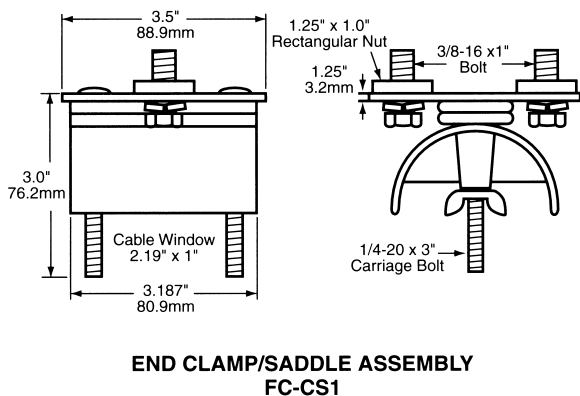

STEP 7 INSTALL INTERMEDIATE TROLLEYS

Insert intermediate trolleys into the C-track. Be sure all trolleys float freely within the track.

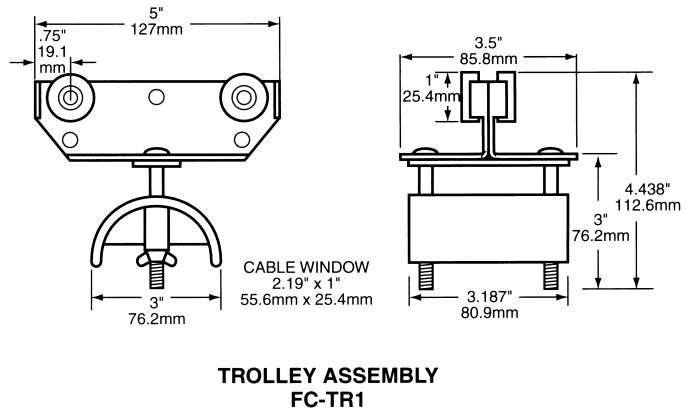

STEP 8 INSTALL LEAD TROLLEY

Insert the lead trolley as the last of the trolleys. When installing a pushbutton track, see Step 13.

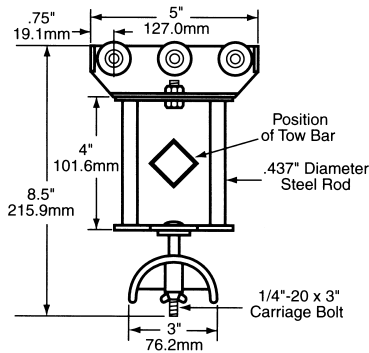

**LEAD TROLLEY
FC-TRT1**

STEP 9 INSTALL END STOP

Install the end stop assembly on the track end opposite the end clamp. Slide the end stop into the slot of the C-Track end and securely tighten the nut.

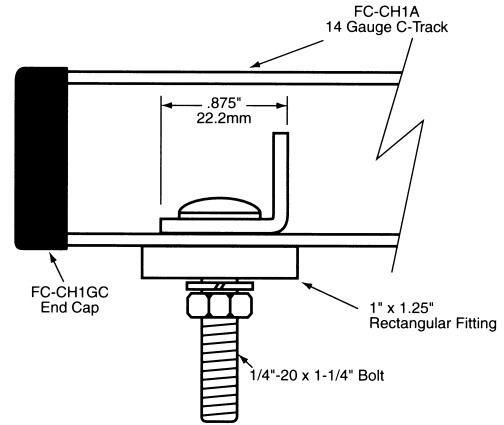

**END STOP ASSEMBLY
FC-CH1G**

STEP 10 INSTALL FLAT CABLE

Feed the flat cables into the trolleys between the plastic clamp pad and the saddle. Loop lengths should be equal and to the depth determined in step one. Duct-O-Wire cable markings are two feet apart from any word in the first marking to the same word in the next marking. If you measure off 3 markings from one saddle clamp to the next, you will have a 3 ft. loop drop. If you go to the 4th mark, you will have a 4 ft. loop drop.

STEP 11 INSTALL JUNCTION BOXES

Install cable connectors on approved junction boxes and insert cables through the rubber bushings. Tighten the connector nut firmly. The connector should be installed at the bottom of the junction box for outdoor applications. Heat shrink cable fittings are available for multiple cable installations.

STEP 12 INSTALL TOW BAR

Install the tow bar on equipment to be electrified. The tow bar should be centered within the tow trolley.

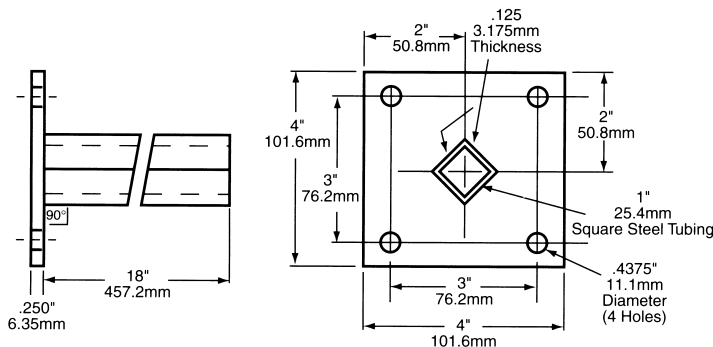

**TOW BAR
FC-TB1**

STEP 13 INSTALL CONTROL TROLLEY

If your system utilizes an independent push button track, install the control trolley as the lead item and attach a junction box. Feed the cables through the saddle into the junction box and secure them with cable connectors.

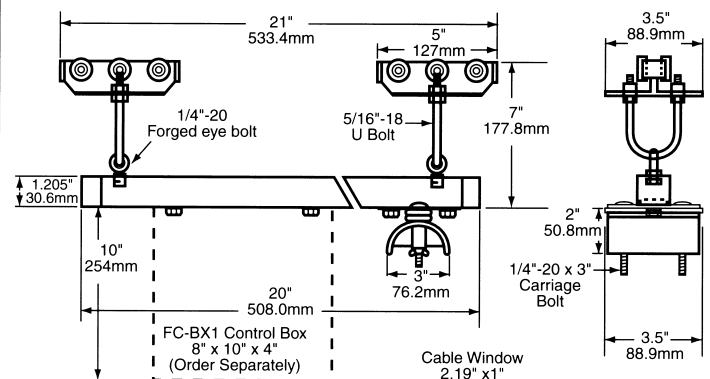

**CONTROL TROLLEY ASSEMBLY
FC-TRC1**

STEP 14 CURVED SECTIONS

Curved sections must be welded to the straight sections. Slide the welding sleeve onto the track where the curved and straight sections meet. Weld a bead around the entire edge of the sleeve. For 45° offset, cut a 90° offset curve section in half.

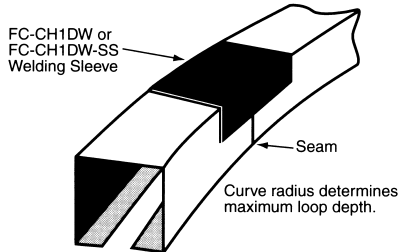

STEP 15 TEST INSTALLATION

Run the entire system back and forth several times over the entire track length to ensure proper operation. Flat cables should extend in a straight line if cables are fastened properly on trolleys. Use cable ties or organizers at the bottom of multiple cable loads to prevent cable twisting or separation.

Warning: Be sure that the cable loop from the lead trolley saddle to the hoist/trolley connections does not place any side pull on the lead trolley. Cable loops must clear all other equipment.

OPTIONAL TROLLEYS

For additional trolley models, see brochure and price list.

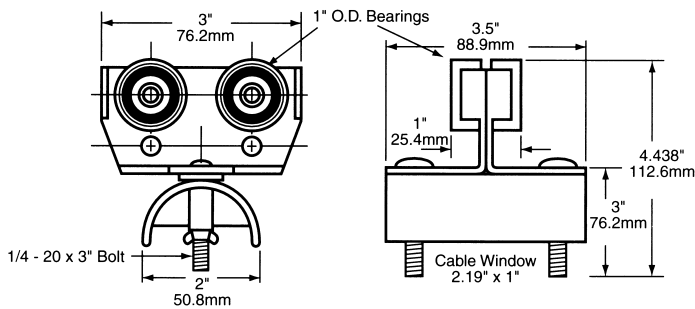

**TROLLEY ASSEMBLY
FC-TR2**

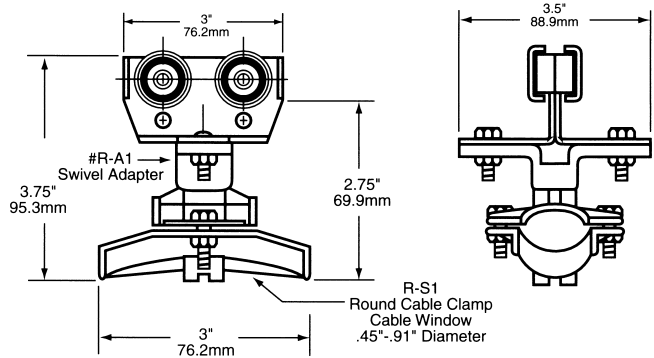

**TROLLEY ASSEMBLY
R-TR2A**

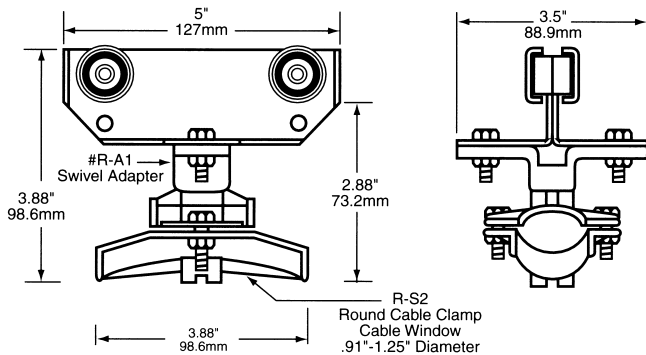

**TROLLEY ASSEMBLY
R-TR1B**

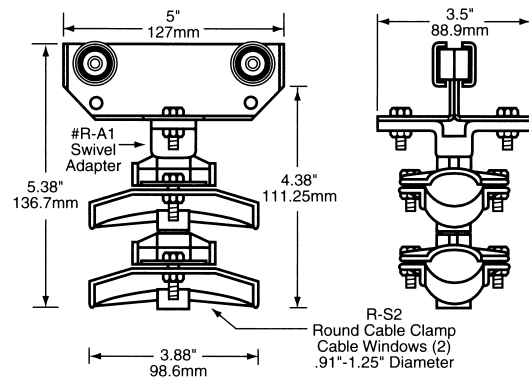

**TROLLEY ASSEMBLY (2 TIER)
R-TR1B-2**