



HURRICANE™

HAND CHAIN HOIST



LIFT AND POSITION FROM VIRTUALLY ANY ANGLE.

Because of its unique design, the versatility and safety benefits of the CM Hurricane 360° beats the competition. This one-of-a-kind hand chain hoist is ideal for use in the following applications:

TIGHT SPACES

where the rigid handle of a lever hoist would be difficult to maneuver and operate. The Hurricane 360° allows you to easily work around obstructions.

ABOVE THE LOAD

where traditional hoists cannot be used. The Hurricane 360°'s rotating hand chain guide allows for operation from virtually any angle.

DRIFTING APPLICATIONS

when the hand chain angle needs to adjust throughout the operation. Using two Hurricane 360° hoists in tandem, operators can easily drift loads from one location to another.

TO MAINTAIN SAFE DISTANCE

while handling a load. The rotating chain guide on the Hurricane 360° lets you conveniently maneuver a load without standing under or near it.



TABLE OF CONTENTS

- 4 **CM HURRICANE 360°**
Hook-mounted hoist models
- 8 **CM HURRICANE 360°**
Army-type, integrated trolley hoist models
- 14 **YALELIFT 360° ATEX**
Hook-mounted and army-type,
integrated trolley hoist models
with explosion protection, spark
resistance and corrosion resistance





HURRICANE™ HAND CHAIN HOIST

360°

The CM Hurricane 360° is unlike any other hand chain hoist on the market today. Featuring a one-of-a-kind hand chain cover, the CM Hurricane 360° provides flexibility and versatility for challenging applications.

The Hurricane's patented hand chain cover rotates a full 360 degrees, allowing loads to be lifted, positioned or pulled from virtually any angle – even in confined spaces. It also permits the operator to stand safely away from the load, helping to prevent accidents and injuries.

HOOK-MOUNTED HOISTS

**1/2 TO 20 TON CAPACITIES
STANDARD LIFTS UP TO 30 FT.**

BENEFITS & FEATURES

PATENTED HAND CHAIN COVER

Unique rotating hand chain cover allows the chain to rotate a full 360 degrees for safe and efficient operation from any direction. Cover design promotes smooth movement of the chain.

TRUSTED RELIABILITY & SAFETY

The Weston-style braking system provides positive load control and reliable performance. Standard load limiter provides simple, automatic overload protection to prevent injuries.

RUGGED & DURABLE FOR LONG LIFE

Internal gears and pinions are made of heat-treated steel for high strength and long life. Powder-coated finish provides protection against corrosion. Precision 4-pocket liftwheel and chain guide provide better chain fit and alignment to reduce wear.

EASE OF MAINTENANCE

Hoist requires minimal maintenance and can be easily disassembled with standard tools.

FAST & EASY PARTS ACCESS

Genuine CM Hurricane 360° parts are available in Total Repair Kits and convenient bulk packaging through CM Parts Star™.

MEETS ASME B30.16 & EUROPEAN CE STANDARD

ADDITIONAL OPTIONS AVAILABLE

Units are available with a variety of options to suit your application, including:

- Chain containers
- Zinc-plated load and hand chain
- Latchlok hooks
- Without standard load limiter



**LIFETIME
WARRANTY™**

CM Hurricane 360° Hook-Mounted Hoist | 20-TON CAPACITY



The CM Hurricane 360° is available as a **hook-mounted hoist** in capacities from 1/2 to 20 tons, with standard lifts up to 30 feet.



1/2-TON
CAPACITY

1-TON
CAPACITY

2-TON
CAPACITY

3-TON
CAPACITY

5-TON
CAPACITY



10-TON
CAPACITY



15-TON
CAPACITY

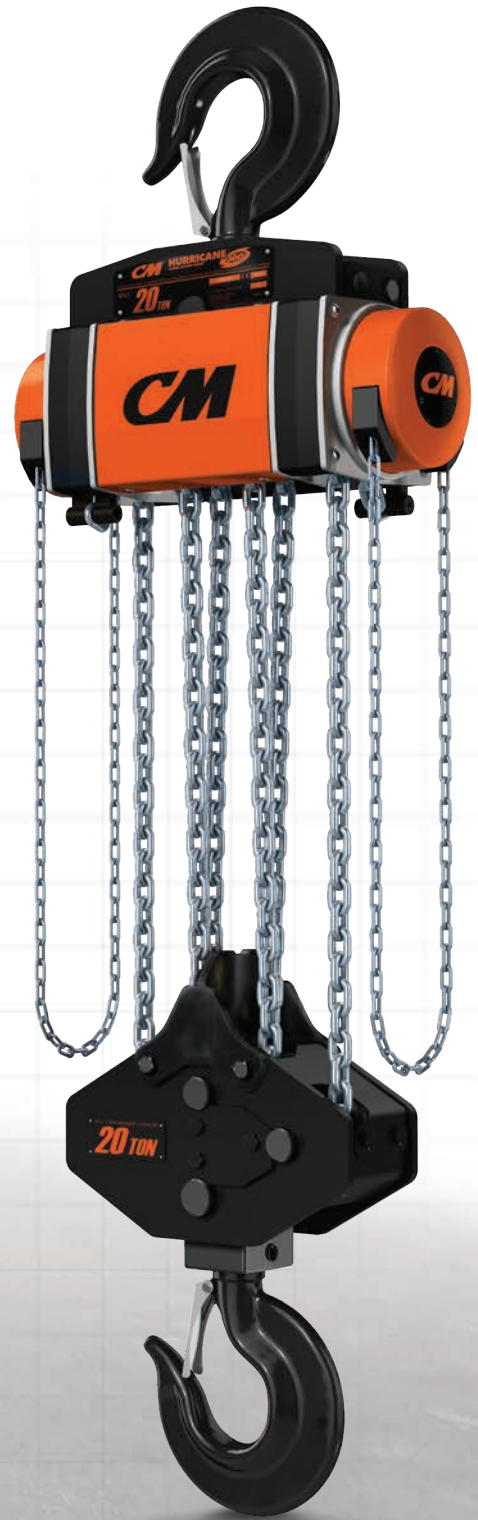

20-TON
CAPACITY

HOOK-MOUNTED HOISTS

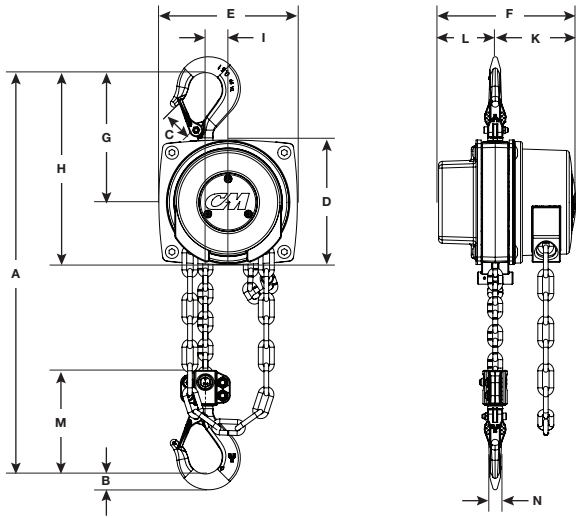

HOOK-MOUNTED HOIST
1/2 TO 3 TON

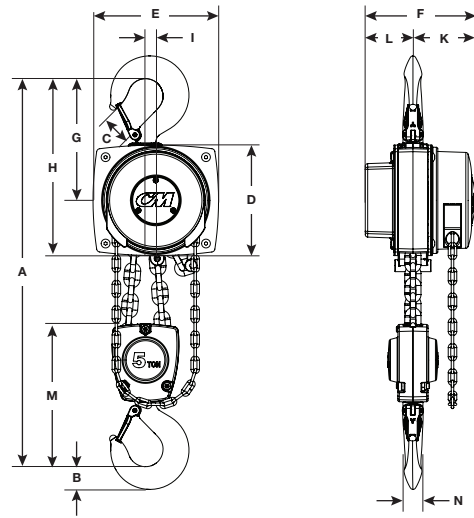

HOOK-MOUNTED HOIST
5 TON

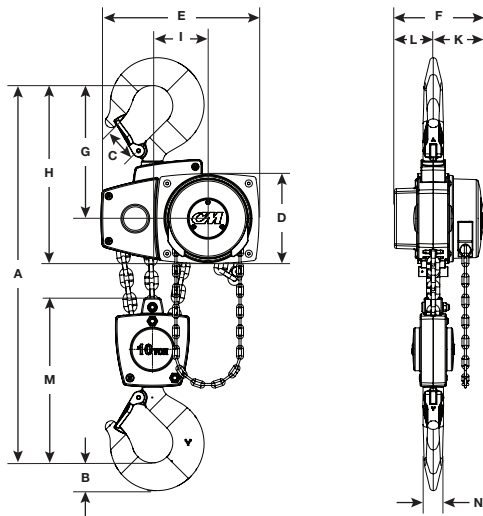

HOOK-MOUNTED HOIST
10 TON

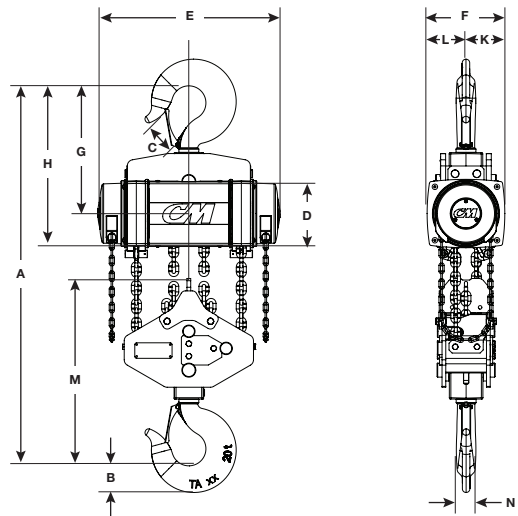

HOOK-MOUNTED HOIST
15 & 20 TON

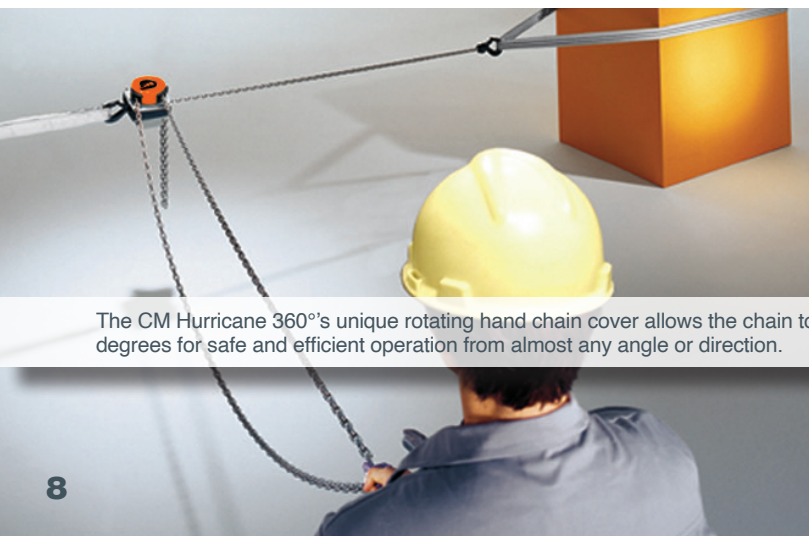

The CM Hurricane 360's unique rotating hand chain cover allows the chain to rotate a full 360 degrees for safe and efficient operation from almost any angle or direction.

SPECIFICATIONS & DIMENSIONS

Product Code	Capacity Ton (kg)	Lift		Weight lbs. (kg)	Reeving	Hand Chain Pull to Lift Rated Load lbs. (kg)	Hand Chain Overhauled to Lift Load One Foot ft. (m)	Dimensions in inches (mm)													
		ft.	m					A	B	C	D	E	F	G	H	I	K	L	M	N	
5623A	1/2 (500)	10	3	21 (9)	1	44 (20)	30 (9.1)	11.811 (300)	0.669 (17)	0.945 (24)	5.236 (133)	5.827 (148)	5.827 (148)	5.472 (139)	8.110 (206)	0.945 (24)	2.402 (61)	3.425 (87)	4.331 (110)	0.551 (14)	
5624A		15	4.5	23 (10)																	
5625A		20	6	25 (11)																	
5651A		30	9	29 (13)																	
5632A		Less Chain		17 (8)																	
5626A	1 (1,000)	10	3	28 (13)	1	54 (24)	49 (14.9)	13.189 (335)	0.866 (22)	1.142 (29)	6.142 (156)	6.890 (175)	6.575 (167)	6.457 (164)	9.528 (242)	0.945 (24)	2.756 (70)	3.819 (97)	4.921 (125)	0.748 (19)	
5627A		15	4.5	31 (14)																	
5628A		20	6	34 (15)																	
5653A		30	9	40 (18)																	
5633A		Less Chain		23 (10)																	
5629A	2 (2,000)	10	3	47 (21)	1	74 (34)	71 (21.6)	15.551 (395)	1.181 (30)	1.378 (35)	7.165 (182)	7.992 (203)	7.638 (194)	7.559 (192)	11.142 (283)	1.220 (31)	3.268 (83)	4.370 (111)	6.142 (156)	0.866 (22)	
5630A		15	4.5	52 (24)																	
5631A		20	6	57 (26)																	
5634A		30	9	66 (30)																	
5635A		Less Chain		36 (16)																	
5635A	3 (3,000)	10	3	75 (34)	1	92 (42)	87 (26)	20.472 (520)	1.496 (38)	1.575 (40)	8.661 (220)	9.843 (250)	8.622 (219)	8.858 (225)	13.189 (335)	1.339 (34)	3.740 (95)	4.882 (124)	7.008 (178)	1.181 (30)	
5636A		15	4.5	82 (37)																	
5637A		20	6	89 (40)																	
5638A		30	9	99 (45)																	
5639A		Less Chain		52 (24)																	
5639A	5 (5,000)	10	3	106 (48)	2	76 (34)	174 (53)	25.748 (654)	1.772 (45)	1.850 (47)	8.661 (220)	9.843 (250)	8.622 (219)	9.528 (242)	13.858 (352)	0.827 (21)	3.740 (95)	4.882 (124)	11.220 (285)	1.457 (37)	
5640A		15	4.5	121 (55)																	
5641A		20	6	136 (62)																	
5642A		30	9	151 (68)																	
5643A		Less Chain		74 (34)																	
5643A	10 (10,000)	10	3	217 (98)	3	102 (46)	261 (79.3)	32.480 (825)	2.677 (68)	2.677 (68)	8.661 (220)	15.079 (383)	8.622 (219)	12.835 (326)	17.165 (436)	5.354 (136)	3.740 (95)	4.882 (124)	15.787 (401)	1.969 (50)	
5644A		15	4.5	240 (109)																	
5645A		20	6	261 (118)																	
5646A		30	9	296 (134)																	
5646A		Less Chain		168 (76)																	
HU15000H10	15 (15,000)	10	3	455 (206)	6	2 x 76 (2 x 34)	522 (2 x 261) (159.1 (2 x 79.3))	43.543 (1106)	3.386 (86)	3.150 (80)	8.661 (220)	23.071 (586)	9.843 (250)	16.181 (411)	20.512 (521)	-	4.921 (125)	4.921 (125)	23.740 (603)	2.480 (63)	
HU15000H15		15	4.5	508 (230)																	
HU15000H20		20	6	554 (251)																	
HU15000H30		30	9	653 (296)																	
HU20000H10	20 (20,000)	10	3	455 (206)	6	2 x 102 (2 x 46)	522 (2 x 261) (159.1 (2 x 79.3))	43.543 (1106)	3.386 (86)	3.150 (80)	8.661 (220)	23.071 (586)	9.843 (250)	16.181 (411)	20.512 (521)	-	4.921 (125)	4.921 (125)	23.740 (603)	2.480 (63)	
HU20000H15		15	4.5	508 (230)																	
HU20000H20		20	6	554 (251)																	
HU20000H30		30	9	653 (296)																	

Other lifts available. Contact factory.
Standard Hand Chain drop 2 ft. less than Lift.

DEMAND GENUINE PARTS

When you choose Parts Star™ by Columbus McKinnon, you'll be purchasing genuine Columbus McKinnon parts designed to fit the Hurricane 360° hoist's exact specifications, maintaining warranty requirements and the integrity of the unit's superior design and safety features.

Get everything you need for a complete and professional repair with Parts Star Total Repair Kits. Popular Hurricane 360° repair parts are also available in easy-to-order bulk packaging so the parts you need are always on hand.



PROTECT AGAINST UNSAFE LIFTING CONDITIONS

All CM Hurricane 360° units feature the Tri-Point Hook Inspection™ system to help protect the operator against unsafe lifting conditions. Hurricane 360° load hooks come with 3 distinct raised points the operator can use to measure the hook to detect any indication of overload or deformation.





HURRICANE™ HAND CHAIN HOIST

360°

The CM Hurricane 360° is available as an army-type, integrated trolley hoist, uniquely and smartly designed for a variety of applications. With all of the same great general features as the hook-mounted version, these compact units feature a low-headroom design for use in even the tightest spaces.

ARMY-TYPE, INTEGRATED TROLLEY HOIST

**1/2 TO 20 TON CAPACITIES
STANDARD LIFTS UP TO 30 FT.**

ADDITIONAL FEATURES

LOW HEADROOM DESIGN

The combination of the versatile CM Hurricane 360 with a low-headroom trolley provides even more flexibility in applications with low ceilings or limited space. Trolleys have reduced side clearances and end approach to aid in maneuvering heavy loads in tight spaces.

ADJUSTABLE & VERSATILE

Choose from plain or geared versions. These manual trolleys can be easily adjusted to fit to a wide range of beam widths and profiles due to threaded spindles (e.g. INP, IPE, IPB). Depending on the beam flange width, an adjustment up to 300 mm can be made easily.

SMOOTH OPERATION

Trolley wheels are designed for smooth rolling with pre-lubricated encapsulated ball bearings. Wheels manufactured from fracture-proof steel. Cambered profile suitable for flat and inclined beam profiles. Note: Trolley wheels are designed for a max. beam profile incline of 14% (DIN 1025 - part 1).

BEST-IN-CLASS SAFETY FEATURES

Standard anti-tilt and anti-drop features. Load limiter also comes standard to protect against dangerous overloads. Rubber bumpers optional for added safety.

RUGGED & DURABLE

Steel load bars are connected directly to the hoist frame for added strength and durability.

ADDITIONAL OPTIONS AVAILABLE

Units are available with a variety of options to suit your application, including:

- Chain containers
- Zinc-plated load and hand chain
- Latchlok hooks
- Without standard load limiter
- Trolley guards
- Larger beam trolleys
- Track clamps
- Rubber bumpers

**LIFETIME
WARRANTY™**



**PLAIN
MODEL**



**GEARED
MODEL**

CM Hurricane 360°
Army-Type, Integrated Trolley Hoist
1-TON CAPACITY



THREADED SPINDLE



TROLLEY WHEEL WITH
CAMBERED PROFILE



The CM Hurricane 360° is available as an **army-type, integrated trolley hoist** with standard lifts up to 30 feet.

Plain trolley hoists are available in capacities from 1/2 to 5 tons. Geared trolley hoists (pictured below) are available in capacities from 1/2 to 20 tons.

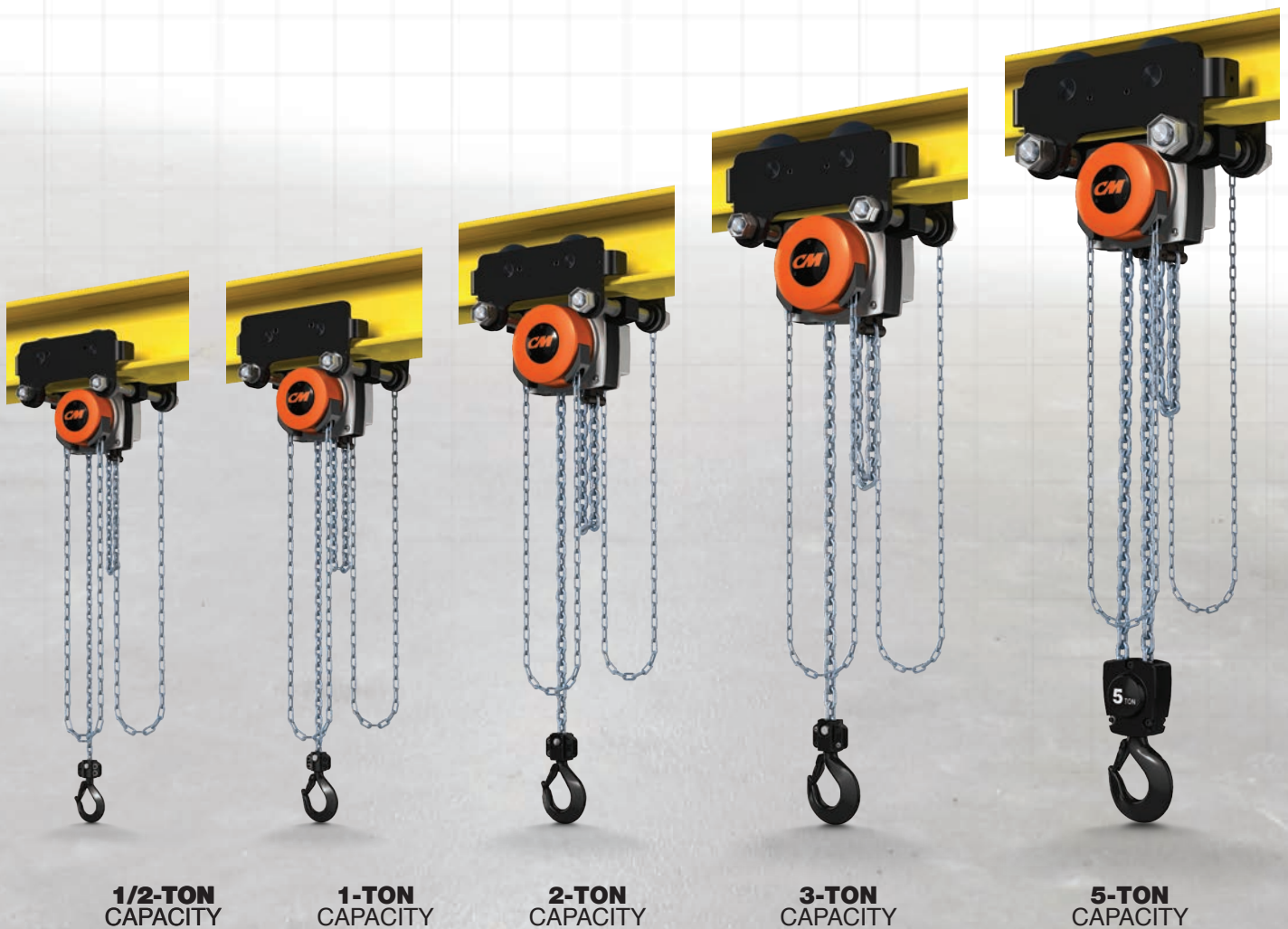

**1/2-TON
CAPACITY**

**1-TON
CAPACITY**

**2-TON
CAPACITY**

**3-TON
CAPACITY**

**5-TON
CAPACITY**



10-TON
CAPACITY



15-TON
CAPACITY



20-TON
CAPACITY

ARMY-TYPE, INTEGRATED TROLLEY HOISTS

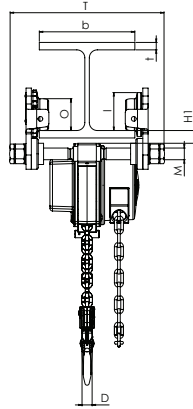
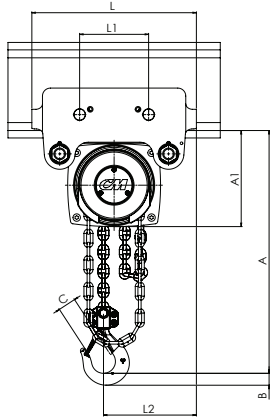

PLAIN TROLLEY HOIST
1/2 TO 3 TON

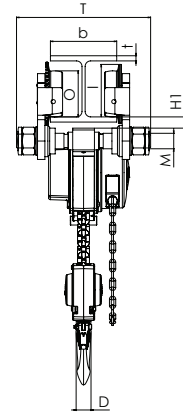
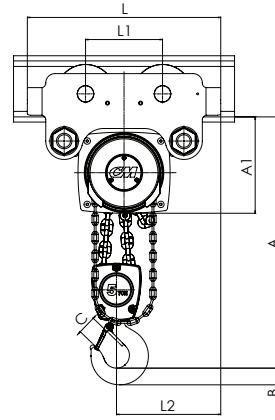

PLAIN TROLLEY HOIST
5 TON

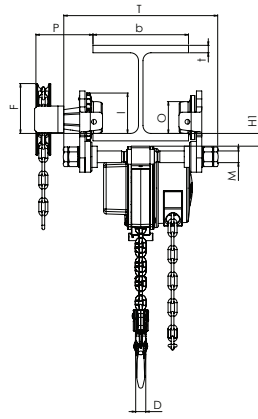
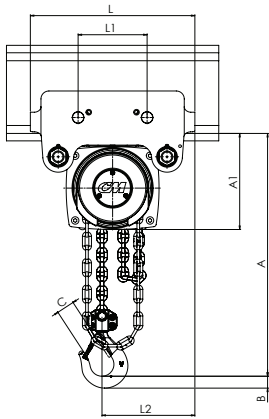

GEARED TROLLEY HOIST
1/2 TO 3 TON

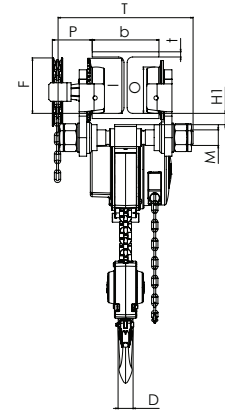
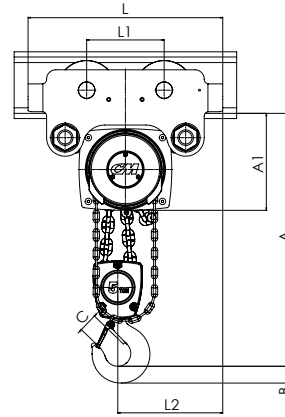

GEARED TROLLEY HOIST
5 TON

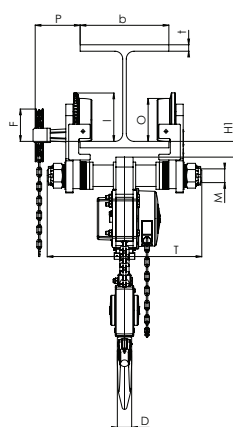
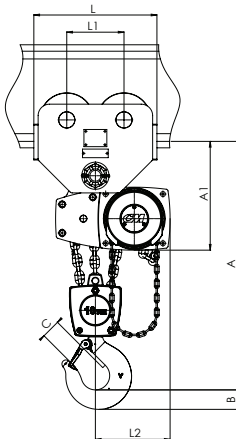

GEARED TROLLEY HOIST
10 TON

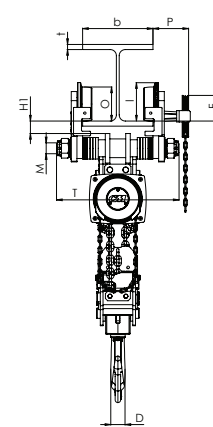
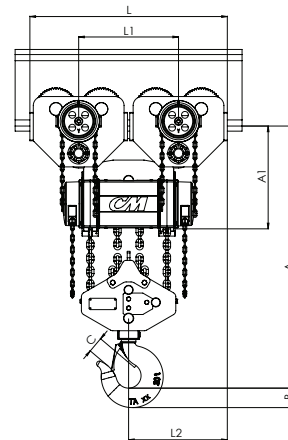

GEARED TROLLEY HOIST
15 & 20 TON

SPECIFICATIONS

Product Code		Capacity Ton (kg)	Lift		Weight (lbs.)				Reeving	Hand Chain Pull to Lift Rated Load lbs. (kg)	Hand Chain Overhauled to Lift Load One Foot ft. (m)	Beam Flange Thickness in. (mm)	Standard Flange Adjustment Range in. (mm)	Minimum Radius Curve ft. (m)
Plain Trolley	Gearred Trolley		ft.	m	Plain Trolley A	Gearred Trolley A	Plain Trolley B	Gearred Trolley B						
HU500PA10	HU500GA10	1/2 (500)	10	3	44	53	46	55	1	44 (20)	30 (9.1)	0.74 (19)	"A" Size* 3.94 to 7.09 (100 to 180)	2.95 (0.9)
HU500PA15	HU500GA15		15	4.5	45	54	48	57						
HU500PA20	HU500GA20		20	6	47	56	51	60						
HU500PA30	HU500GA30		30	9	50	59	56	65						
HU1000PA10	HU1000GA10	1 (1,000)	10	3	60	71	64	73	1	54 (24)	49 (14.9)	0.74 (19)	"A" Size* 3.94 to 7.09 (100 to 180)	2.95 (0.9)
HU1000PA15	HU1000GA15		15	4.5	62	73	66	75						
HU1000PA20	HU1000GA20		20	6	65	76	69	78						
HU1000PA30	HU1000GA30		30	9	70	81	74	83						
HU2000PA10	HU2000GA10	2 (2000)	10	3	97	108	101	110	1	74 (34)	71 (21.6)	0.74 (19)	"A" Size* 3.94 to 7.09 (100 to 180)	3.77 (1.15)
HU2000PA15	HU2000GA15		15	4.5	102	113	106	115						
HU2000PA20	HU2000GA20		20	6	106	117	110	119						
HU2000PA30	HU2000GA30		30	9	115	126	119	128						
HU3000PA10	HU3000GA10	3 (3,000)	10	3	170	181	174	185	1	92 (42)	87 (26)	1.06 (27)	"A" Size* 3.94 to 7.09 (100 to 180)	A=4.92 B=4.59 (A=1.5) (B=1.4)
HU3000PA15	HU3000GA15		15	4.5	177	188	181	192						
HU3000PA20	HU3000GA20		20	6	184	195	188	199						
HU3000PA30	HU3000GA30		30	9	198	209	202	213						
HU5000PA10	HU5000GA10	5 (5,000)	10	3	275	286	284	295	2	76 (34)	174 (53)	1.06 (27)	"A" Size* 3.94 to 7.09 (100 to 180)	A=6.56 B=5.91 (A=2.0) (B=1.8)
HU5000PA15	HU5000GA15		15	4.5	289	300	298	309						
HU5000PA20	HU5000GA20		20	6	304	315	313	324						
HU5000PA30	HU5000GA30		30	9	333	344	342	353						
-	HU10000GB10	10 (10,000)	10	3	-	-	-	445	3	102 (46)	261 (79.3)	1.57 (40)	"B" Size 7.09 to 11.81 (180 to 300)	5.91 (1.8)
-	HU10000GB15		15	4.5	-	-	-	466						
-	HU10000GB20		20	6	-	-	-	488						
-	HU10000GB30		30	9	-	-	-	531						
-	HU15000GB10	15 (15,000)	10	3	-	-	-	894	6	2 x 76 (2 x 34)	522 (2 x 261) (159.1 (2 x 79.3))	1.57 (40)	"B" Size 7.09 to 11.81 (180 to 300)	31.17 (9.5)
-	HU15000GB15		15	4.5	-	-	-	936						
-	HU15000GB20		20	6	-	-	-	978						
-	HU15000GB30		30	9	-	-	-	1062						
-	HU20000GB10	20 (20,000)	10	3	-	-	-	894	6	2 x 102 (2 x 46)	522 (2 x 261) (159.1 (2 x 79.3))	1.57 (40)	"B" Size 7.09 to 11.81 (180 to 300)	31.17 (9.5)
-	HU20000GB15		15	4.5	-	-	-	936						
-	HU20000GB20		20	6	-	-	-	978						
-	HU20000GB30		30	9	-	-	-	1062						

Other lifts available. Contact factory.

Standard hand chain drop 2 ft. less than lift.

* 1/2 to 5 ton units also available with an optional "B size" flange adjustment range of 7.09 to 11.81 inches.

DIMENSIONS

Product Code		Capacity Ton (kg)	Dimensions in inches (mm)																
Plain Trolley	Gearred Trolley		A	A1	B	C	D	F (Gearred)	H1	I Plain	I Gearred	L	L1	L2	M	O	P (Gearred)	T (A Size)	T (B Size)
HU500PA10	HU500GA10	1/2 (500)	9.65 (245)	6.22 (158)	0.67 (17)	0.94 (24)	0.55 (14)	3.62 (92)	0.96 (24.5)	2.81 (71.5)	3.01 (76.5)	10.63 (270)	5.12 (130)	6.26 (159)	M18	2.36 (60)	4.25 (108)	11.02 (280)	15.75 (400)
HU500PA15	HU500GA15		10.71 (272)	7.01 (178)	0.87 (22)	1.14 (29)	0.75 (19)	3.62 (92)	0.94 (24)	2.81 (71.5)	3.01 (76.5)	12.2 (310)	5.12 (130)	6.89 (175)	M22	2.36 (60)	4.33 (110)	11.42 (290)	16.14 (410)
HU2000PA10	HU2000GA10		12.72 (323)	8.09 (205.5)	1.18 (30)	1.38 (35)	0.87 (22)	3.58 (91)	0.93 (23.5)	3.76 (95.5)	3.86 (98)	14.17 (360)	5.91 (150)	8.15 (207)	M27	3.15 (80)	4.41 (112)	12.01 (305)	16.73 (425)
HU3000PA10	HU3000GA10		15.04 (382)	9.92 (252)	1.5 (38)	1.57 (40)	1.18 (30)	4.21 (107)	1.26 (32)	5.16 (131)	5.22 (132.5)	17.52 (445)	7.09 (180)	10.08 (256)	M30	4.41 (112)	4.41 (112)	12.6 (320)	17.32 (440)
HU5000PA10	HU5000GA10	5 (5,000)	21.65 (550)	10.26 (260.5)	1.77 (45)	1.85 (47)	1.46 (37)	5.89 (149.5)	1.2 (30.5)	5.61 (142.5)	5.85 (148.5)	20.67 (525)	8.23 (209)	11.14 (283)	M42	4.92 (125)	4.61 (117)	14.33 (364)	19.06 (484)
-	HU10000GB10		30.87 (784)	14.96 (380)	2.68 (68)	2.68 (68)	1.97 (50)	4.45 (113)	2.17 (55)	-	6.65 (169)	16.93 (430)	7.87 (200)	10.28 (261)	M48	5.91 (150)	6.22 (158)	-	21.26 (540)
-	HU15000GB15		45.47 (1155)	17.83 (453)	3.39 (86)	2.52 (64)	2.2 (56)	4.45 (113)	2.17 (55)	-	6.65 (169)	34.25 (870)	17.32 (440)	17.13 (435)	M48	5.91 (150)	6.22 (158)	-	21.26 (540)
-	HU20000GB10		45.47 (1155)	17.83 (453)	3.39 (86)	2.52 (64)	2.2 (56)	4.45 (113)	2.17 (55)	-	6.65 (169)	34.25 (870)	17.32 (440)	17.13 (435)	M48	5.91 (150)	6.22 (158)	-	21.26 (540)



YALELIFT 360™ ATEX

HAND CHAIN HOIST

The Yalelift 360™ ATEX hand chain hoist is the ideal manual hoist for harsh environments. Exceeding requirements for a classic hand chain hoist, the Yalelift 360 ATEX is built for use in explosive atmospheres and features a unique patented hand chain cover that rotates a full 360 degrees to lift loads from virtually any angle.

YALELIFT 360™ ATEX HAND CHAIN HOIST

**1/4 TO 12 TON CAPACITIES
STANDARD LIFTS UP TO 10 FT.
OTHER LIFTS AVAILABLE UPON REQUEST.**

FEATURES & BENEFITS

EXPLOSION PROTECTION & SPARK RESISTANCE

Designed for explosive environments with spark-resistant, copper-coated suspension and load hooks; stainless steel load chain and hand chain; and bronze trolley wheels.

CORROSION RESISTANT

Enclosed robust stamped steel housing protects internal components, even in the toughest conditions. Chain guide and internal gearbox are partially enclosed for protection in harsh environments.

For maximum corrosion protection, we use the MKS micro corrosion protection system consisting of Delta-Protekt® KL100 basecoat and Delta Seal® topcoat.

Delta Protekt® is an inorganic, micro-porous, layer-forming basecoat barrier with overlapping zinc and aluminum flakes that result in high anti-corrosion silver metallic properties. This basecoat layer helps ensure electrical conductivity so that the desired cathodic protection of the iron is present.

Delta Seal® is an organic, highly cross-linked microcrystalline, layer-forming topcoat that provides a firm chemical-resistant coating.

This two-coat system guarantees high-level protection against corrosion.

MEETS ATEX REQUIREMENTS

Hoist meets EU standards 2014/34/EU and 99/92/EC.

ULTIMATE VERSATILITY

Patented hand chain cover rotates a full 360 degrees to allow loads to be lifted, pulled or positioned from virtually any angle. In addition to providing maximum versatility, this unit offers a convenient way to maneuver loads without standing under the load.

LOW HEADROOM

Extremely low headroom allows for maximum use of the lifting height.

FEATURES & BENEFITS CONT.

TRUSTED RELIABILITY

- Braking power of our Weston-style braking system provides positive load control and reliable performance. Zinc plated or yellow chromated to protect against corrosion.
- Minimal maintenance and easily disassembled with no special tools.

BUILT TO LAST

- All internal gears and pinions are made of heat-treated steel for high strength and long life.
- Precision 4-pocket liftwheel and chain guide provide better chain fit and alignment, reducing wear and increasing chain life.

SUPERIOR HOOK DESIGN

Drop-forged load and suspension hooks made of high-tensile steel yield under overload instead of breaking. Hooks rotate 360° and are fitted with robust safety latches.

OPTIONAL OVERLOAD PROTECTION

Load Limiter™ offers simple, automatic overload protection.

MEETS ASME B30.16 & EUROPEAN CE STANDARD



**THE YALELIFT 360™ ATEX
HAND CHAIN HOIST**

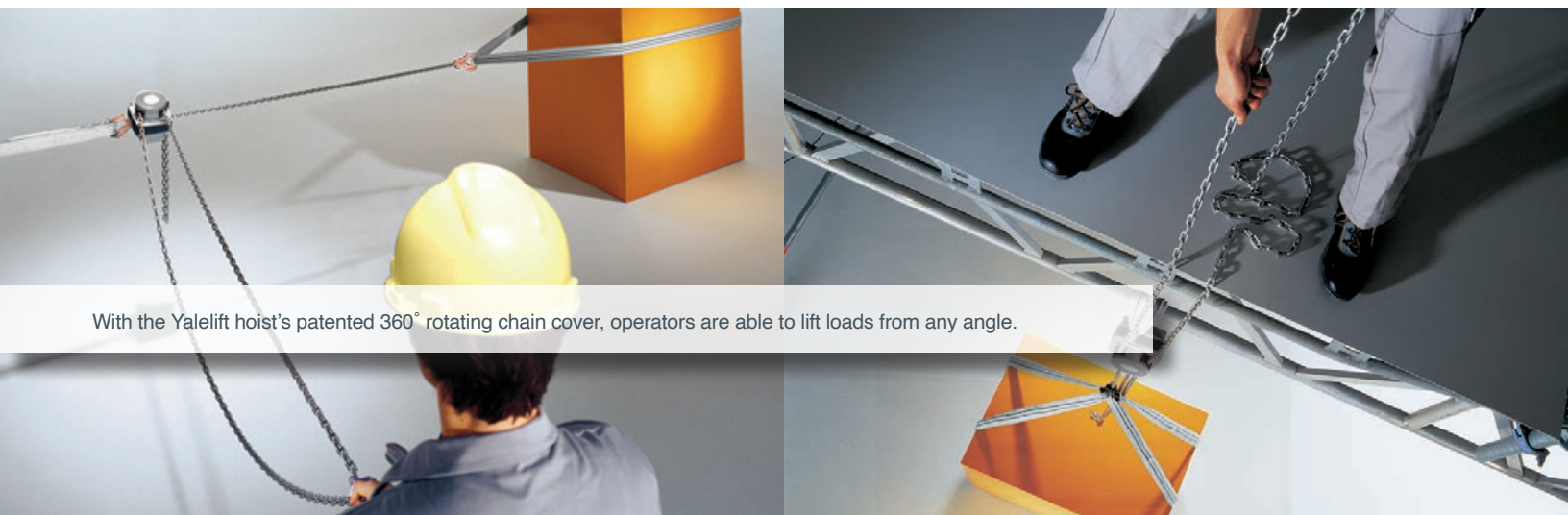

With the Yalelift hoist's patented 360° rotating chain cover, operators are able to lift loads from any angle.



YALELIFT 360 ATEX II 2 GD C IIC T4

Model Number	Product Code	Standard Lift (ft.)	Capacity (tons)	Chain Dimensions d x p (mm)	Chain Falls	Hand Chain Over-Hauled to Lift One Meter	Pull on Hand Chain at WLL daN	Weight lb. (kg)
YL ATEX 250	192021793	10	1/4	.24 x .71 (6 x 18)	1	49	30	28.6 (13)
YL ATEX 500	192021796	10	1/2					
YL ATEX 1000	192021797	10	1					
YL ATEX 1500	192021798	10	1-1/2					
YL ATEX 2000	192021799	10	2					
YL ATEX 3000	192021800	10	3	.39 x 1.18 (10 x 30)	2	174	34	83.7 (38)
YL ATEX 4000	192021801	10	4					
YL ATEX 5000	192021802	10	5					
YL ATEX 6000	192021803	10	6					
YL ATEX 8000	192021804	10	8					
YL ATEX 10000	192021805	10	10					
YL ATEX 12000	192021806	10	12					
					3	261	44	156.5 (71)
					6	552	2 x 44	432.1 (196)

YALELIFT ITP ATEX WITH INTEGRATED PUSH-TYPE TROLLEY II 2 GD C IIC T4

Model Number	Product Code	Standard Lift (ft.)	Capacity (tons)	Size*	Beam Flange Width b inches (mm)	Beam Flange Thickness t max. inches (mm)	Curve Radius min. ft. (m)	Weight lb. (kg)	Weight with Locking Device lb. (kg)
YLITP ATEX 250	192021814	10	1/4	A	1.97 - 7.08 (50 - 180)	.75 (19)	29.52 (0.9)	59.5 (27)	77.1 (35)
YLITP ATEX 500	192021815	10	1/2	A					
YLITP ATEX 1000	192021816	10	1	A					
YLITP ATEX 1500	192021817	10	1 1/2	A	2.91 - 7.08 (74 - 180)	10.67 (27)	4.92 (1.5)	169.7 (77)	189.5 (86)
YLITP ATEX 2000	192021818	10	2	A					

*Size B on request.

YALELIFT ITG ATEX WITH INTEGRATED GEARED-TYPE TROLLEY II 2 GD C IIC T4

Model Number	Product Code	Standard Lift (ft.)	Capacity (tons)	Size*	Beam Flange Width b inches (mm)	Beam Flange Thickness t max. inches (mm)	Curve Radius Min. ft. (m)	Weight lb. (kg)	Weight with Locking Device lb. (kg)
YLITG ATEX 250	192021819	10	1/4	A	1.97 - 7.09 (50 - 180)	0.75 (19)	29.52 (0.9)	70.5 (32)	88.1 (40)
YLITG ATEX 500	192021821	10	1/2	A					
YLITG ATEX 1000	192021822	10	1	A					
YLITG ATEX 1500	192021823	10	1 1/2	A	2.91 - 7.09 (74 - 180)	1.06 (27)	4.92 (1.5)	180.7 (82)	200.6 (91)
YLITG ATEX 2000	192021824	10	2	A					
YLITG ATEX 3000	192021825	10	3	A	3.85 - 7.09 (98 - 180)	1.06 (27)	6.56 (2.0)	286.6 (130)	308.6 (140)
YLITG ATEX 4000	192021826	10	4	A					
YLITG ATEX 5000	192021827	10	5	B	4.92 - 12.20 (125 - 310)	1.57 (40)	5.9 (1.8)	on request	on request
YLITG ATEX 6000	192021828	10	6	B					
YLITG ATEX 8000	192021829	10	8	B	7.09 - 12.20 (180 - 310)	1.57 (40)	16.4 (5.0)	on request	on request
YLITG ATEX 10000	192021830	10	10	B					
YLITG ATEX 12000	192021831	10	12	B					

*Size B on request.

DIMENSIONS YALELIFT 360 ATEX

Capacity (ton)	Dimensions in. (mm)												
	A	B	C	D	E	F	G	H	I	K	L	M	N
¼, ½ & 1	13.19 (335)	0.87 (22)	1.14 (29)	6.14 (156)	6.89 (175)	6.58 (167)	6.46 (164)	9.53 (242)	0.95 (24)	2.76 (70)	3.82 (97)	4.92 (125)	0.75 (19)
1½ & 2	20.47 (520)	1.50 (38)	1.58 (40)	8.66 (220)	9.84 (250)	8.62 (219)	8.86 (225)	13.19 (335)	1.34 (34)	3.74 (95)	4.88 (124)	7.01 (178)	1.18 (30)
3 & 4	25.75 (654)	1.77 (45)	1.85 (47)	8.66 (220)	9.84 (250)	8.62 (219)	9.53 (242)	13.86 (352)	0.83 (21)	3.74 (95)	4.88 (124)	11.22 (285)	1.46 (37)
5 & 6	32.48 (825)	2.68 (68)	2.68 (68)	8.66 (220)	15.08 (383)	8.62 (219)	12.84 (326)	17.17 (436)	5.35 (136)	3.74 (95)	4.88 (124)	15.79 (401)	1.97 (50)
8, 10 & 12	39.76 (1010)	3.35 (85)	2.52 (64)	11.93 (303)	21.85 (555)	9.84 (250)	15.39 (391)	19.72 (501)	-	15.59 (396)	4.92 (125)	18.54 (471)	2.21 (56)

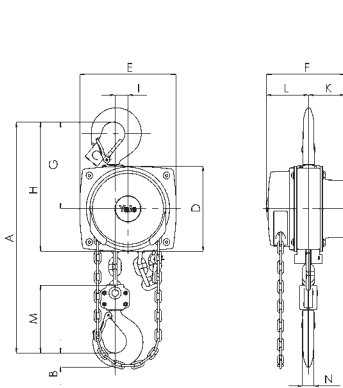

**YALELIFT 360 ATEX, SINGLE FALL
1/4 TO 2 TON**

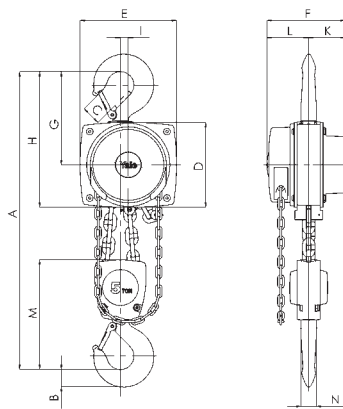

**YALELIFT 360 ATEX, DOUBLE FALL
3 TO 4 TON**

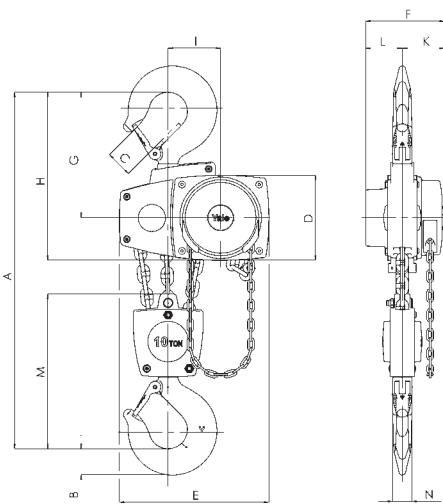

**YALELIFT 360 ATEX, THREE FALL
5 TO 6 TON**

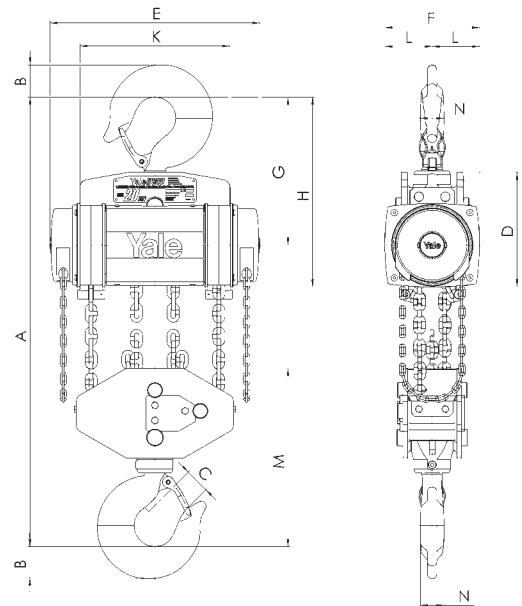

**YALELIFT 360 ATEX, SIX FALL
8 TO 12 TON**

DIMENSIONS YALELIFT IT ATEX

Capacity (ton)	Dimensions in. (mm)																	
	A min.	A1	A2	B	C	D	F Geared trolley	H1	I Pushed trolley	I Geared trolley	L	L1	L2	M	O	P Geared trolley	T (Area A)	T (Area B)
1/4, 1/2 & 1	10.71 (272)	7.01 (178)	-	0.87 (22)	1.14 (29)	0.75 (19)	3.62 (92)	0.94 (24)	2.81 (71.5)	3.01 (76.5)	12.20 (310)	5.12 (130)	6.89 (175)	M 22	2.36 (60)	4.33 (110)	11.42 (290)	16.14 (410)
1-1/2 & 2	15.04 (382)	9.92 (252)	-	1.50 (38)	1.57 (40)	1.18 (30)	4.21 (107)	1.26 (32)	5.16 (131)	5.22 (132.5)	17.52 (445)	7.09 (180)	10.08 (256)	M 30	4.41 (112)	4.41 (112)	12.60 (320)	17.32 (440)
3 & 4	21.65 (550)	10.26 (260.5)	-	1.77 (45)	1.85 (47)	1.46 (37)	5.89 (149.5)	1.20 (30.5)	5.61 (142.5)	5.85 (148.5)	20.67 (525)	8.23 (209)	11.14 (283)	M 42	4.92 (125)	4.61 (117)	14.33 (364)	19.06 (484)
5 & 6	30.87 (784)	14.96 (380)	-	2.68 (68)	2.68 (68)	1.97 (50)	4.45 (113)	2.17 (55)	6.65 (169)	6.65 (169)	16.93 (430)	7.87 (200)	10.28 (261)	M 48	5.91 (150)	6.22 (158)	-	21.26 (540)

Dimensions for 8, 10 & 12-ton capacities available upon request.

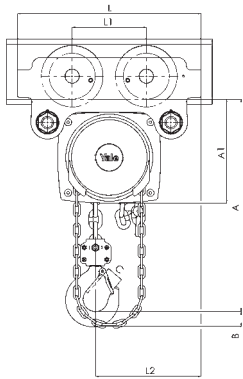

YALELIFT ITP ATEX, SINGLE FALL
1/4 TO 2 TON

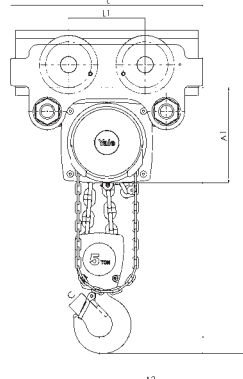
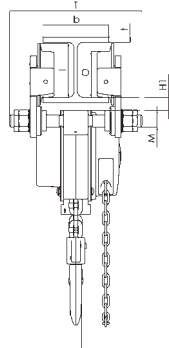

YALELIFT ITG ATEX, DOUBLE FALL
3 TO 4 TON

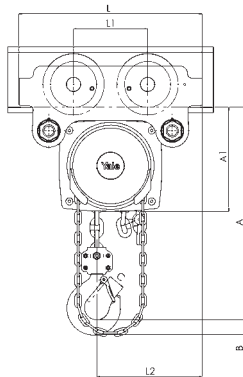
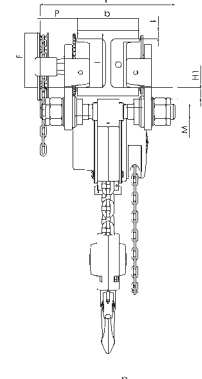
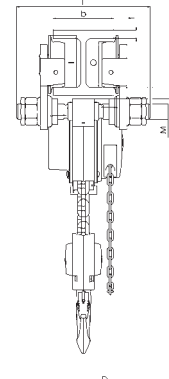

YALELIFT ITG ATEX, SINGLE FALL
1/4 TO 2 TON

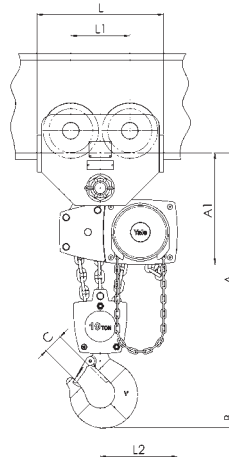
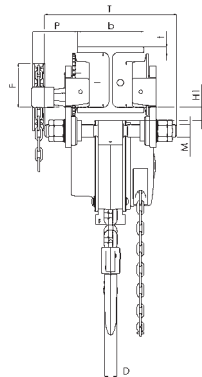

YALELIFT ITG ATEX, THREE FALL
5 TO 6 TON

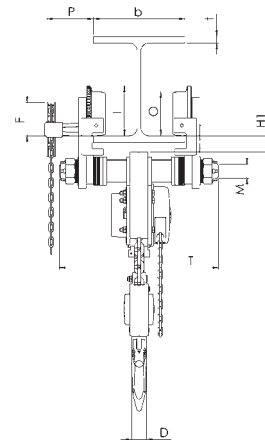



**LIFT AND POSITION
FROM VIRTUALLY ANY ANGLE.**



YOUR ONE SOURCE FOR FLOOR-TO-CEILING SYSTEMS

Since 1875, Columbus McKinnon has helped to make material handling easier and safer, and, today, is your single source for complete floor-to-ceiling lifting systems.

From below-the-hook attachments, chain, rigging products, manual and powered chain hoists to electric wire rope hoists, cranes, enclosed track systems and specially engineered products, Columbus McKinnon has the engineering expertise to meet the most demanding applications.



KNOW HOW. KNOW WHY.

Columbus McKinnon is committed to providing expert safety training on the proper use and inspection of rigging and overhead lifting equipment. Our company offers comprehensive programs at our national training centers as well as on-site at your facility. Courses include:

- Hoist Maintenance
- Safe Hoisting
- Rigging Gear Inspection
- Crane & Hoist Inspection
- Load Securement
- Crane Operator Training
- Rigging



Win in the marketplace with **CMCO University™**. This three-day program is designed to give Channel Partners intimate product and application knowledge that they can use to advise their end-user customers during the product selection and sales processes.

Columbus McKinnon's corporate headquarters in Getzville, New York, is home to our state-of-the-art **Niagara Training Center**. The 3,000-square-foot facility is dedicated to training Channel Partners and end users on the safe and proper use of hoist and rigging products. The Center offers a one-of-a-kind training experience on chain and rigging equipment with more than 75 manual and powered hoists, enclosed track systems and our 50-foot-wide crane system with 3-ton Yale Global King wire rope hoist.



USA 800.888.0985 • 716.689.5400 • fax: 716.689.5644

CDN 877.264.6478 • fax: 877.264.6477

www.cmworks.com

